

RANGE  
**4WD**  
4 WHEEL DRIVE

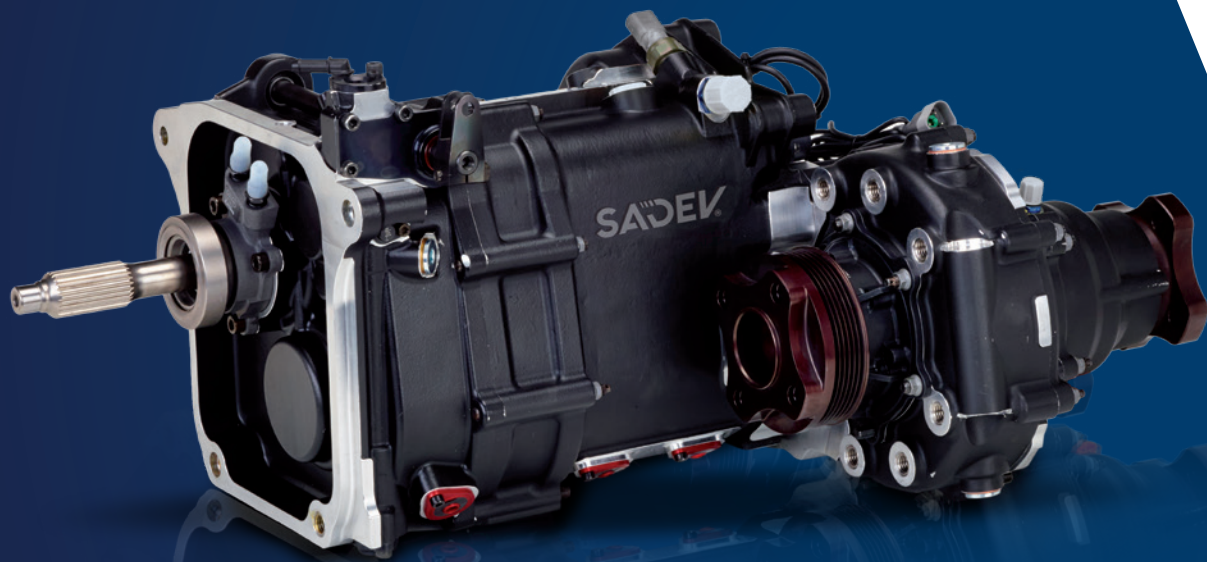

 **SC924**  
TRANSAXLE

**SADEV**<sup>®</sup>  
RACING TRANSMISSION

**SADEV**  
RACING TRANSMISSION

RANGE  
**4WD**  
4 WHEEL DRIVE

**SC924**  
TRANSAXLE



Tackling even the trickiest terrain, the **SC924** is a benchmark in the off-road world. Its weight-focused design, compactness and robustness make it the weapon of choice for rally raid. Innovations such as the low-friction differential and the optimised tooth profiles make it the ideal solution for your future projects.

## APPLICATIONS

- › *Drift*
- › *Rally-Raid*



## TECHNICAL SPECS

6 speed sequential gearbox + 1 reverse gear

Manual sequential gear selection

Wide range of final drives available

Wide range of ratios available

Straight cut gears

Dog ring gear engagement

Interchangeable gear ratios

High strength carburizing steel

Gear teeth grinded with optimized profile

Shot penning on internal parts

Specific input shaft

Central limited slip differential (optional low friction)

Ramp and plate system

Wide range of ramp plates available

Differential locking system

Reverse lockout cable (solenoid system optional)

Contactless gear position sensor

Contactless flat shift sensor

Directed and pressurised lubrication on the gears

Oil suction screen

Magnetic drain plugs

Painted AS7G aluminum casings

Angle possible  $-15^{\circ}$  to  $195^{\circ}$

Weight (input shaft included) : 58 Kg - 127 lbs

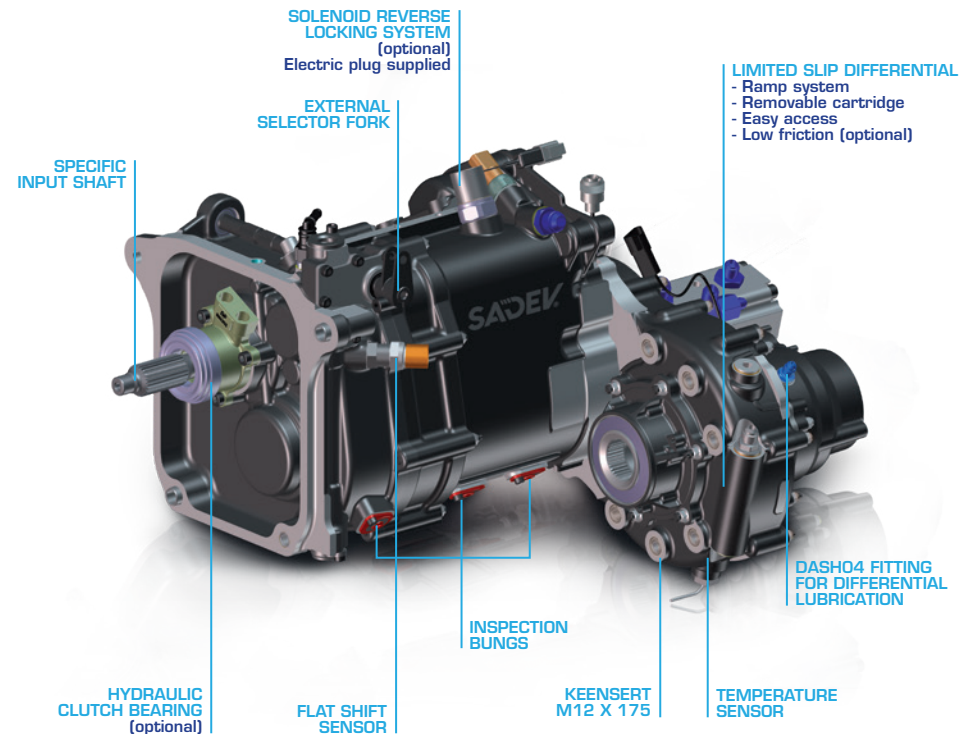
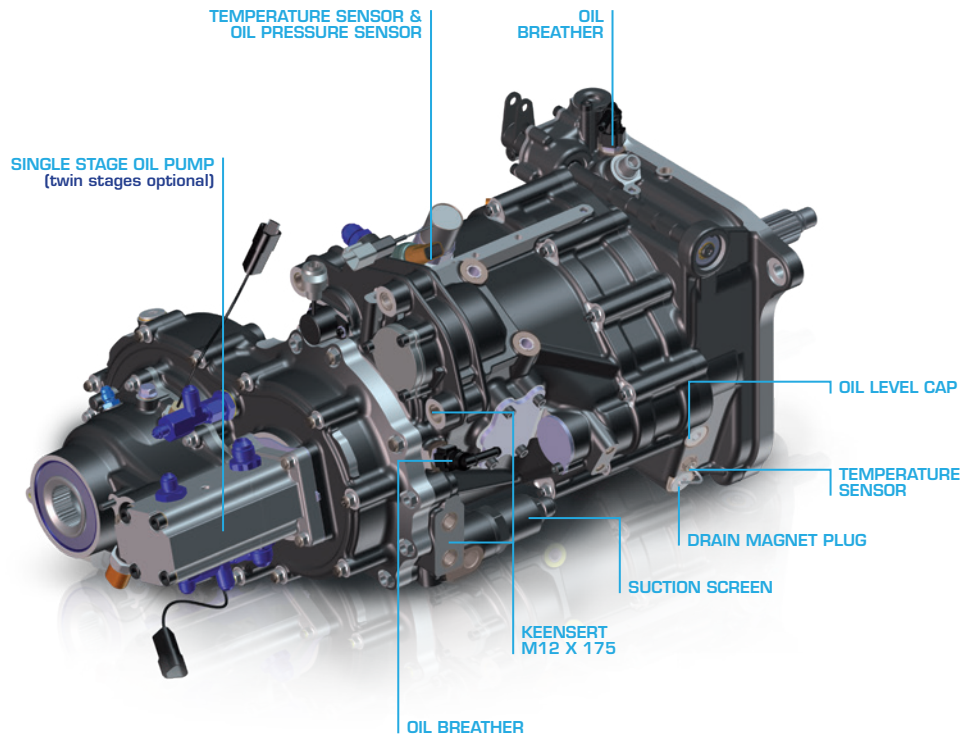

## ACCESSORIES

- › Gearlever
- › Gear Display
- › Bell housing
- › Propshaft

### LIMITED SLIP DIFFERENTIAL

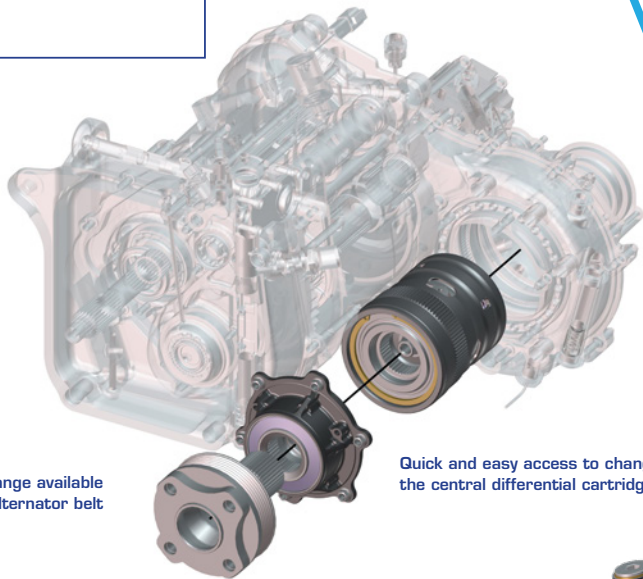

Output pulley flange available to drive an alternator belt

Quick and easy access to change the central differential cartridge

### REPLACEABLE DROP GEAR

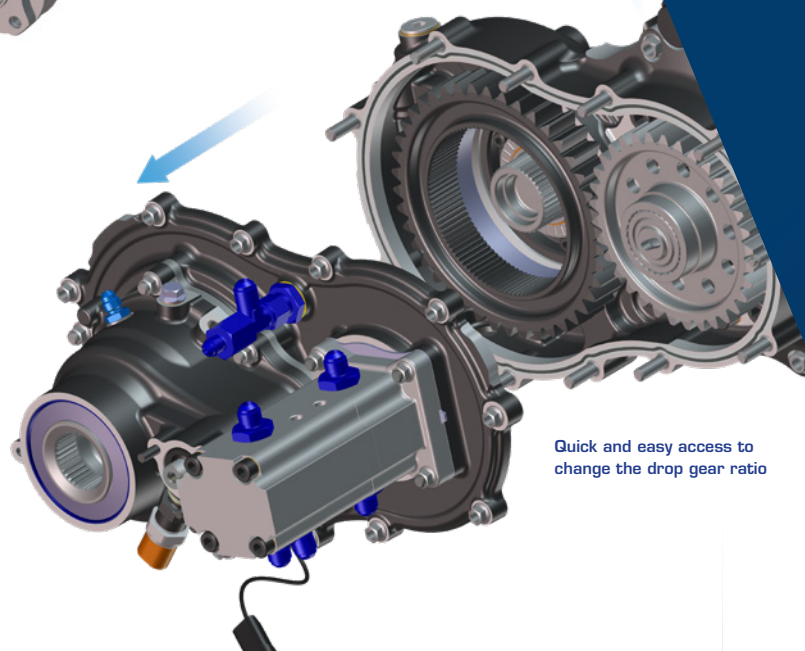

Quick and easy access to change the drop gear ratio

### TRANSFER CASE ANGLES

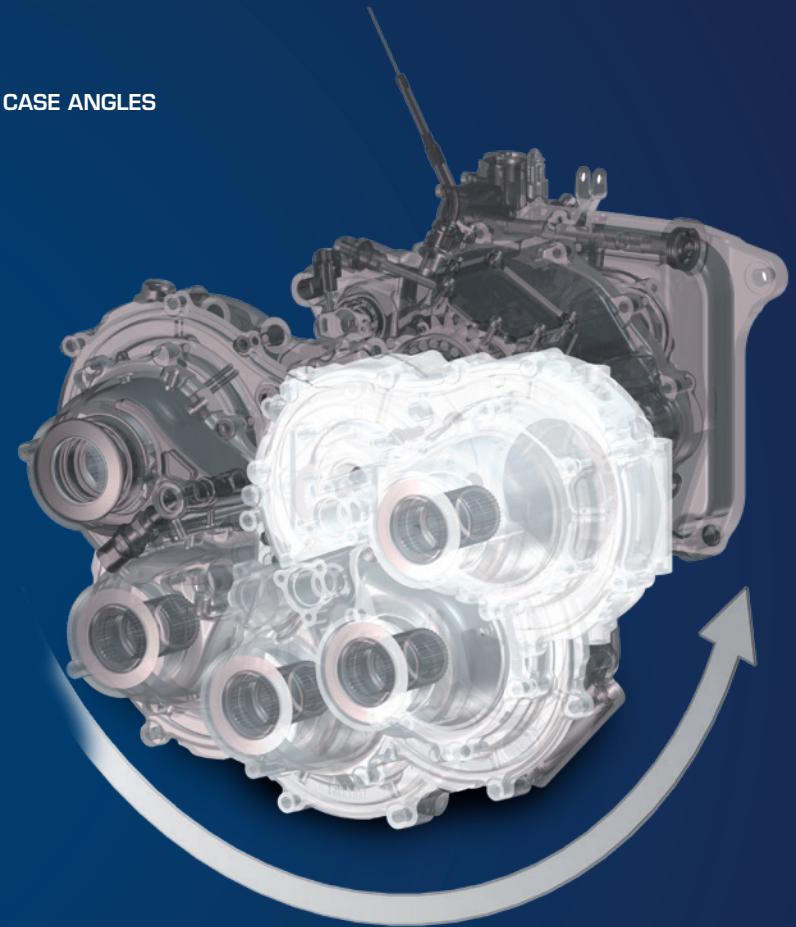

The transfer case can rotate from  $-15^{\circ}$  to  $195^{\circ}$ .



## SC924 TRANSAXLE

- › **Reliability:** With several Dakar rallies proving its reliability on all types of terrain, the **SC924** is a benchmark in its field.
- › **Robustness:** Our finite element calculation tool enables us to design extremely strong, compact, lightweight casings.
- › **Architecture:** The offset geartrains mean the engine and gearbox can be positioned as low as possible.
- › **Gears:** The **SC924** benefits from optimised and strengthened gear tooth profiles for maximum efficiency.
- › **Ratio selection:** Optimised clutch and control shaft definition for smoother gear shifting.
- › **Limited slip self-locking ramp differential:** Optimised teeth version available as an option.
- › **Differential locking:** Option to lock the central differential mechanically.

### MAXIMUM ENGINE TORQUE





## ONE PASSION: VICTORY

SADEV has an exceptional record in supplying unique engineering to the most prestigious drivers and manufacturers. SADEV's products stand out for their technology, their excellence and their ambition. As precise as they are reliable, these high-tech masterpieces are the key to your victory. SADEV has just one goal: to make sure you win.

FOLLOW US



[WWW.SADEV-TM.COM](http://WWW.SADEV-TM.COM)

6, rue Grand'Montains - 85110 SAINT-PROUANT - FRANCE

Tel: +33 (0)2 51 66 42 68

[sadev@sadev-tm.com](mailto:sadev@sadev-tm.com)



## A TEAM AT YOUR SIDE

<b>FRANCE</b>	SADEV FRANCE - <a href="mailto:sadev@sadev-tm.com">sadev@sadev-tm.com</a>
<b>USA</b>	SADEV TRANSMISSIONS, INC. - <a href="mailto:info.usa@sadev-tm.com">info.usa@sadev-tm.com</a>
<b>UK</b>	SWR MOTORSPORT LTD - <a href="mailto:serviceswrmotorsport@gmail.com">serviceswrmotorsport@gmail.com</a>
<b>ITALY</b>	GIEFFE RACING - <a href="mailto:info@giefferacing.com">info@giefferacing.com</a>
<b>SPAIN</b>	DE LA PUENTE MOTORSPORT - <a href="mailto:dlpmotorsport@movistar.es">dlpmotorsport@movistar.es</a>
<b>NETHERLANDS</b>	RACING DEVELOPMENT - <a href="mailto:info@racingdevelopment.nl">info@racingdevelopment.nl</a>
<b>NETHERLANDS</b>	PETERS AUTOSPORT - <a href="mailto:bart@petersautosport.nl">bart@petersautosport.nl</a>
<b>BELGIUM</b>	R TEC - <a href="mailto:info@rtec.ws">info@rtec.ws</a>
<b>CZECH REPUBLIC</b>	SADAC - <a href="mailto:info@sadac.cz">info@sadac.cz</a>
<b>GERMANY</b>	MTO ENGINEERING - <a href="mailto:info@mtoengineering.com">info@mtoengineering.com</a>
<b>SWEDEN</b>	HANSEN MOTORSPORT - <a href="mailto:kenneth@hansen-motorsport.se">kenneth@hansen-motorsport.se</a>
<b>DENMARK</b>	GUNNAR AASKOV MOTORSPORT - <a href="mailto:mail@aaaskov-motorsport.dk">mail@aaaskov-motorsport.dk</a>
<b>FINLAND</b>	SET PROMOTION - <a href="mailto:kalle.pinomaki@setpromotion.com">kalle.pinomaki@setpromotion.com</a>
<b>SWITZERLAND</b>	CHRISTIAN FERRARI - <a href="mailto:ferrach@bluewin.ch">ferrach@bluewin.ch</a>
<b>SOUTH AFRICA</b>	CENTURY RACING - <a href="mailto:julien@centuryracing.co.za">julien@centuryracing.co.za</a>
<b>ARGENTINA</b>	JPO RACING - <a href="mailto:racingjpo@gmail.com">racingjpo@gmail.com</a>
<b>BRAZIL</b>	CD MOTORSPORT ENGINEERING - <a href="mailto:sadev.brasil@gmail.com">sadev.brasil@gmail.com</a>

